

# Series 803 "Mighty Mouse" 1/4 Turn Bayonet Coupling



Series 803

## Series 803 Bayonet Crimp Receptacles



**Push-To-Mate, 1/4 Turn to Lock.**  
These quick-mating connectors feature bayonet pins on the receptacle. Simply push the connectors together, then rotate the plug coupling nut 90° to lock the connectors together.





**Three Shell Mounting Options:**  
Jam nut with o-ring for rear panel mounting, elliptical flange for front or rear panel mounting, or in-line receptacles for free-hanging cables.

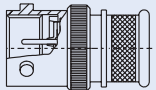
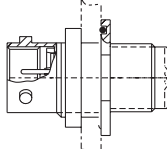
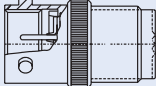

**Two Shell Styles:** Choose the integral band platform for direct attachment of a cable shield. Install a heat-shrink boot, or overmold directly onto the band platform. An accessory thread is available for attaching strain reliefs and backshells.

### HOW TO ORDER

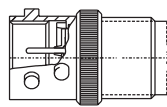
Sample Part Number					
803-003	-07	NF	6-7	S	N
Series	Shell Style	Shell Material / Finish	Shell Size- Insert Arrangement	Contact Type	Shell Key Position
<b>803-003</b> Receptacle with Banding Platform for Direct Attachment of Cable Shield and Overmold 	<b>-07</b> Jam Nut 	<b>C</b> Aluminum / Black Anodize  <b>M</b> Aluminum / Electroless Nickel  <b>NF</b> Aluminum / Cadmium with Olive Drab Chromate  <b>ZN</b> Aluminum / Zinc-Nickel with Olive Drab Chromate  <b>ZNU</b> Aluminum / Zinc-Nickel with Black Chromate  <b>Z1</b> Stainless Steel / Passivated	<b>5-3</b> 3 #23 Contacts <b>6-1</b> 1 #16 Contact <b>6-4</b> 4 #23 Contacts <b>6-7</b> 7 #23 Contacts <b>7-1</b> 1 #12 Contact <b>7-10</b> 10 #23 Contacts <b>8-13</b> 13 #23 Contacts <b>9-4</b> 4 #16 Contacts <b>9-19</b> 19 #23 Contacts <b>10-26</b> 26 #23 Contacts <b>12-2</b> 2 #12 Contacts <b>12-37</b> 37 #23 Contacts <b>14-55</b> 55 #23 Contacts <b>15-85</b> 85 #23 Contacts  #23 contacts are packaged with connectors. #16 and #12 contacts must be ordered separately.	Standard #23 contacts accept #22 through #28 AWG wire. Use the following contact codes to specify these contacts:  <b>P</b> Pin  <b>S</b> Socket  Special contacts for #26 to #30 AWG are also available. Use the following contact codes to specify these contacts:  <b>G</b> Pin  <b>H</b> Socket	<b>N</b> Normal  Alternate Key Positions: <b>X</b> <b>Y</b> <b>Z</b>
<b>803-004</b> Receptacle with Rear Accessory Thread 	<b>-02</b> Flange Mount 				
	<b>-01</b> In-Line 				

F

## Series 803 Jam Nut Crimp Receptacle Dimensions

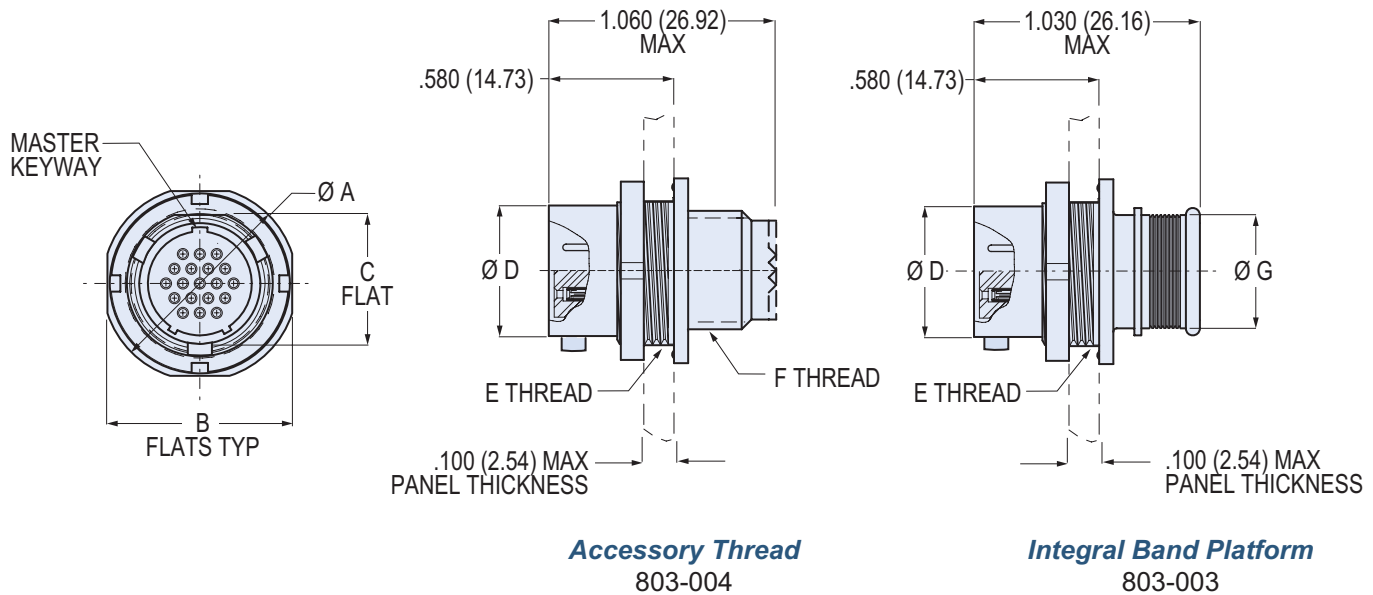

Accessory Thread  
803-004

Integral Band Platform  
803-003

### DIMENSIONS

Shell Size	Ø A		B Flats		C Flat		Ø D		E Thread	F Thread	Ø G	
	In.	mm.	In.	mm.	In.	mm.	In.	mm.			In.	mm.
5	.575	14.61	.545	13.84	.350	8.89	.300	7.62	.3750-32 UNEF-2A	.2500-32 UNEF-2A	.230	5.84
6	.635	16.13	.595	15.11	.410	10.41	.362	9.19	.4375-28 UNEF-2A	.3125-32 UNEF-2A	.286	7.26
7	.755	19.18	.723	18.36	.536	13.61	.436	11.07	.5625-32 UN-2A	.4375-28 UNEF-2A	.390	9.91
8	.755	19.18	.723	18.36	.536	13.61	.508	12.91	.5625-32 UN-2A	.5625-24 UNEF-2A	.440	11.18
9	.830	21.08	.790	20.07	.596	15.14	.561	14.25	.6250-28 UN-2A	.5625-24 UNEF-2A	.500	12.70
10	.890	22.61	.855	21.72	.656	16.66	.635	16.13	.6875-28 UN-2A	.6250-28 UNEF-2A	.562	14.27
12	1.078	27.38	1.044	26.52	.845	21.46	.714	18.14	.8750-28 UN-2A	.6875-24 UNEF-2A	.650	16.51
14	1.264	32.11	1.230	31.24	1.022	25.96	.865	21.97	1.0625-20 UN-2A	.9375-20 UNEF-2A	.805	20.45
15	1.325	33.66	1.290	32.77	1.096	27.84	.925	23.50	1.1250-28 UN-2A	.9375-20 UNEF-2A	.850	21.59

### ALTERNATE KEY POSITIONS

Pos.	A°	B°
N	150°	210°
X	75°	210°
Y	95°	230°
Z	140°	275°

### JAM NUT PANEL CUTOUT

Shell Size	A Flat		Ø B	
	In. ± .002	mm. ± 0.05	In.	mm.
5	.360	9.14	.385	9.78
6	.420	10.67	.448	11.38
7	.551	13.99	.573	14.55
8	.551	13.99	.573	14.55
9	.609	15.47	.635	16.13
10	.666	16.92	.698	17.73
12	.859	21.82	.885	22.48
14	1.038	26.37	1.075	27.31
15	1.111	28.22	1.135	28.83

# Series 803 "Mighty Mouse" 1/4 Turn Bayonet Coupling



Series 803

## Series 803 Flange Mount Crimp Receptacle

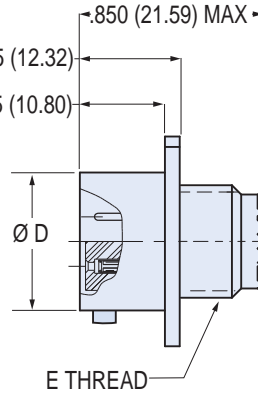
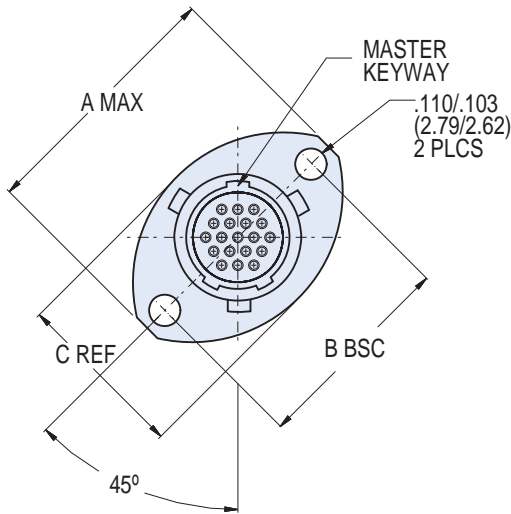

**Accessory Thread**  
803-004

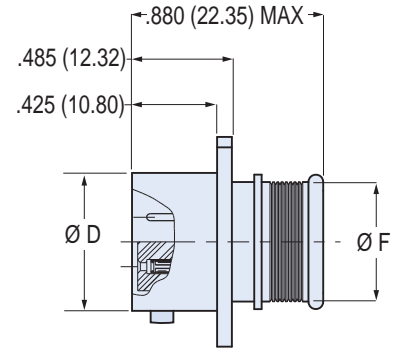

**Integral Band Platform**  
803-003

### DIMENSIONS

Shell Size	A Max.		B Bsc.		C Ref.		Ø D		E Thread	Ø F	
	In.	mm.	In.	mm.	In.	mm.	In.	mm.		In.	mm.
5	.703	17.86	.513	13.03	.460	11.68	.300	7.62	.2500-32 UNEF-2A	.230	5.84
6	.788	20.02	.598	15.19	.522	13.26	.362	9.19	.3125-32 UNEF-2A	.286	7.26
7	.890	22.61	.708	17.98	.590	14.99	.436	11.07	.4375-28 UNEF-2A	.390	9.91
8	1.154	29.31	.964	24.49	.668	16.97	.508	12.91	.4375-28 UNEF-2A	.440	11.18
9	1.207	30.66	1.017	25.83	.721	18.31	.561	14.25	.5625-24 UNEF-2A	.500	12.70
10	1.291	32.79	1.101	27.97	.795	20.19	.635	16.13	.4375-28 UNEF-2A	.562	14.27
12	1.394	35.41	1.204	30.58	.874	22.20	.714	18.14	.6875-24 UNEF-2A	.650	16.51
14	1.545	39.24	1.280	32.51	1.050	26.67	.865	21.97	.9375-20 UNEF-2A	.805	20.45
15	1.630	41.4	1.370	34.80	1.150	29.21	.925	23.50	.9375-20 UNEF-2A	.850	21.59

### ALTERNATE KEY POSITIONS

Pos.	A°	B°
N	150°	210°
X	75°	210°
Y	95°	230°
Z	140°	275°

### SERIES 803 PANEL CUTOUTS

Shell Size	A		Ø B	
	In.	mm.	In.	mm.
5	.513	13.03	.365	9.25
6	.598	15.19	.430	10.92
7	.708	17.98	.520	13.21
8	.964	17.98	.592	15.04
9	1.017	25.83	.645	16.38
10	1.101	27.97	.726	18.44
12	1.204	30.58	.832	21.13
14	1.280	32.51	.945	24.00
15	1.370	34.80	1.010	25.65

F

## Series 803 In-Line Crimp Receptacle Dimensions

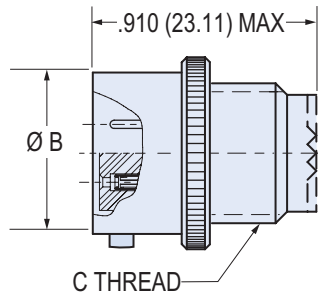
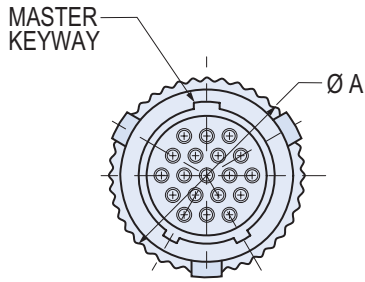

**Accessory Thread**  
803-004

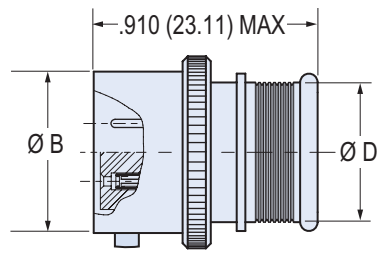

**Integral Band Platform**  
803-004

F

DIMENSIONS								
Shell Size	A Max.		Ø B		C Thread	Ø D		
	In.	mm.	In.	mm.		In.	mm.	
5	.402	10.21	.300	7.62	.2500-32 UNEF-2A	.230	5.84	
6	.465	11.81	.362	9.19	.3125-32 UNEF-2A	.286	7.26	
7	.500	12.70	.436	11.07	.4375-28 UNEF-2A	.390	9.91	
8	.570	14.48	.508	12.90	.5625-24 UNEF-2A	.440	11.18	
9	.652	16.56	.561	14.25	.5625-24 UNEF-2A	.500	12.70	
10	.715	18.15	.635	16.13	.6250-28 UNEF-2A	.562	14.27	
12	.805	20.45	.714	18.14	.6875-24 UNEF-2A	.650	16.51	
14	.915	23.24	.865	21.97	.9375-20 UNEF-2A	.805	20.45	
15	.975	24.77	.925	23.50	.9375-20 UNEF-2A	.850	21.59	

ALTERNATE KEY POSITIONS			
	Pos.	A°	B°
	N	150°	210°
	X	75°	210°
	Y	95°	230°
	Z	140°	275°